

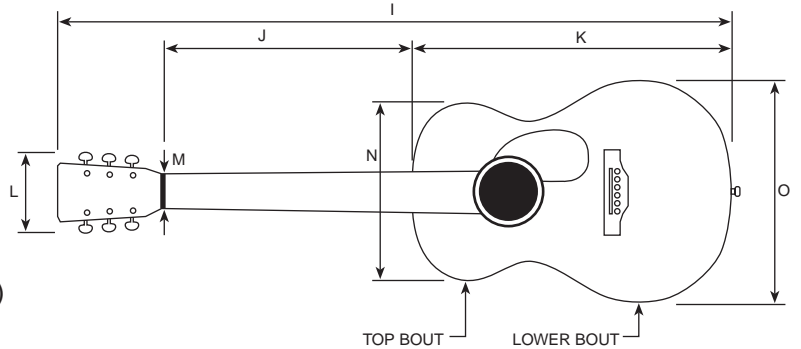

Custom Fitted
Fibreglass
Instrument Cases

GUITAR ORDER FORM

- _____ A - Table to bottom of Head Stock
- _____ B - Table to bottom of Neck at 1st Fret
- _____ C - Table to top of String at 1st Fret
- _____ D - Table to bottom of Neck at 8th Fret
- _____ E - Table to top of String at 8th Fret
- _____ F - Depth of Body at Heel
- _____ G - Depth of Body at End Pin
- _____ H - Table to Top of Saddle
- _____ I - Length of Guitar (overall)
- _____ J - Length of Neck (Nut to Body)
- _____ K - Length of Body
- _____ L - Width of Headstock (Includes Tuners)
- _____ M - Width of Neck at Nut
- _____ N - Width of Body at widest point of Top Bout
- _____ O - Width of Body at widest point of Lower Bout

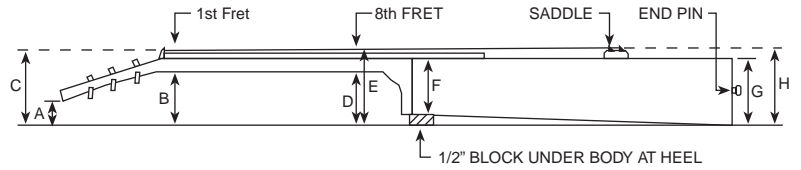

MEASURING INSTRUCTIONS

STEP 1: Place the instrument on a table and rest the Body at the heel on a 1/2" block.

STEP 2: Take measurements to the nearest 1/16".

STEP 3: Make a tracing of the guitar body shape using a reasonable weight paper or light cardboard. Do not use newsprint if at all possible. **CUT OUT YOUR TRACING AND COMPARE IT TO THE BACK OF YOUR GUITAR.** It is important that this tracing is accurate so that we can obtain a good fit for your instrument.

STEP 4: Note anything unusual about your guitar. Does it have any external knobs, pickups, strap pins or anything else that will require special cutting of the padding? If so, please include the measurements for these items and note their exact placement on your plans (see example below.)

STEP 5: Is your guitar a cutaway? Please indicate whether you want the cutaway filled with padding or left open for extra storage.

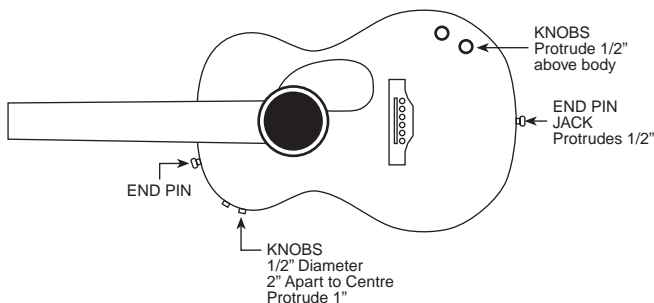

Name: _____

Address: _____

City: _____

Prov/State: _____ Postal/Zip Code: _____

Tel: _____

S.S.N. (USA only): _____

Guitar Make: _____

Model: _____

Personalized nameplate: 2 lines, up to 10 letters per line. Please print the information as it is to appear on the label:

Please see price list for current prices

STANDARD <input type="checkbox"/> or DELUXE <input type="checkbox"/> Case	
EXTERIOR Color (check one): Red <input type="checkbox"/> Green <input type="checkbox"/> Blue <input type="checkbox"/> White <input type="checkbox"/> Brown <input type="checkbox"/> Black <input type="checkbox"/> Grey <input type="checkbox"/>	
INTERIOR Color (check one): Red <input type="checkbox"/> Green <input type="checkbox"/> Silver <input type="checkbox"/> Beige <input type="checkbox"/> Rose <input type="checkbox"/> Black <input type="checkbox"/> Blue <input type="checkbox"/> Wine <input type="checkbox"/>	
LOCKING CATCHES (Specify how many)	
SHOULDER STRAP	
OTHER	
ANOTHER OTHER	
SHIPPING & HANDLING	
SUBTOTAL	
GST (Canadian Residents Only)	
TOTAL ENCLOSED	